

CHAPTER 8: Superstructure (Internal)

CONTENTS

8.1 INTERNAL WALLS

8.2 UPPER FLOORS

8.3 STAIRS

FUNCTIONAL REQUIREMENTS

8.1 INTERNAL WALLS

Workmanship

- i. All workmanship must be within defined tolerances as defined in Chapter 1 of this Manual.
- ii. All work to be carried out by a technically competent person in a workmanlike manner.

Materials

- i. All materials should be stored correctly in a manner which will not cause damage or deterioration of the product.
- ii. All materials, products and building systems shall be appropriate and suitable for their intended purpose.
- iii. The structure shall, unless specifically agreed otherwise with the warranty provider, have a life of not less than 60 years. Individual components and assemblies, not less than 60 years. Individual components and assemblies, not integral to the structure, may have a lesser durability but not in any circumstances less than 15 years.

Design

- i. Design and specifications shall provide a clear indication of the design intent and demonstrate a satisfactory level of performance.
- ii. Structural elements outside the parameters of regional Approved Documents must be supported by structural calculations provided by a suitably qualified expert.
- iii. Party walls between dwellings must achieve satisfactory levels of sound insulation meeting the relevant requirements of the Building Regulations.
- iv. The materials, design and construction must meet the relevant Building Regulations and other statutory requirements. British Standards and Euro-Codes.

8.1.1 Internal masonry walls

8.1.1.1 Foundations

Below ground, load-bearing walls must be supported using a suitable foundation. Where there are upper floors, a suitable beam or lintel is required which can adequately transfer the load to a foundation. Structural masonry walls should be provided with foundations.

8.1.1.2 Compressive strength

The varying strengths of bricks and blocks mean that they have to be chosen in accordance with the proposed use of the building. The recommended strengths of bricks and blocks to be used in buildings up to 3 storeys high are shown in Table 1:

Height of wall	Minimum compressive strength of brick or block unit	
One or two storeys	Blocks	- 2.9N/mm ²
	Bricks	- 9N/mm ²
Lowest storey of a three storey wall or where individual storeys exceed 2.7m	Blocks	- 7.5N/mm ²
	Bricks	- 13N/mm ²
Upper storeys of three storey wall	Blocks	- 2.8N/mm ²
	Bricks	- 9N/mm ²

Table 1: Minimum compressive strength of masonry

8.1.1.3 Lateral restraint

Lateral restraint is to be provided for load-bearing walls and separating walls at each floor level and the ceiling level below a roof.

8.1.1.4 Bonding and tying

Where a separating wall abuts an external wall they may be tied or bonded together.

Tied joints should be formed using expanded metal strip, wall ties or equivalent fixings, at maximum 300mm vertical centres.

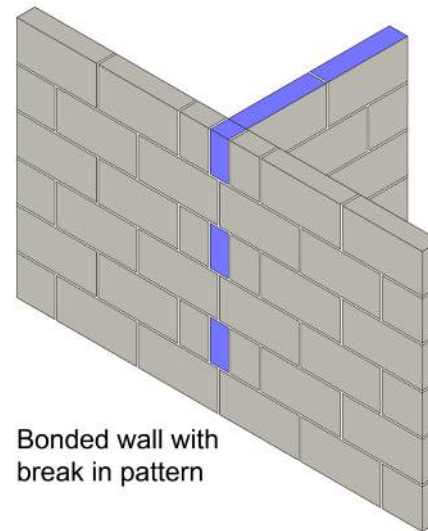

Bonded wall with break in pattern

Figure 1: Bonded walls

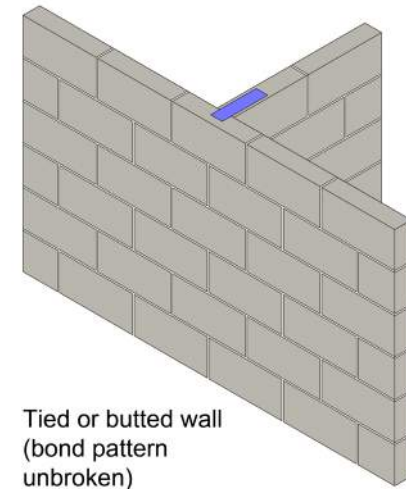

Tied or butted wall (bond pattern unbroken)

Figure 2: Butted and tied walls

The external wall cavity needs to be closed at the junction with the separating wall with a flexible cavity stop, but not if the cavity is fully filled with built-in insulation (where permitted).

8.1.1.5 Wall ties for cavity separating walls

To provide structural stability, normally the two leaves of a masonry cavity separating wall should be tied together. Sound transmission across the cavity should be limited by the type of tie and spacing.

Ties should be specified in accordance with the System Designer's recommendations for timber framed separating walls. The type of tie and spacing should limit sound transmission across the cavity.

To limit sound transmission, metal tie straps should be:

- Not more than 3mm thick;
- Fixed below ceiling level;
- Spaced at least 1.2m apart horizontally.

Thicker ties, fixed at ceiling level or more closely spaced will increase sound transmission through the cavity.

8.1.2 Load-bearing timber walls and partitions

Load-bearing timber internal walls are to be designed to provide support and transfer loads to foundations safely and without undue movement.

Structural design of load-bearing timber walls should be in accordance with BS 5268. Structural timber should be specified according to the strength classes, e.g. C16 or C24.

8.1.2.1 Structural elements

Typically, individual studs, sills and head plates are to be 38mm x 75mm. Larger timber section sizes are required to achieve satisfactory levels of fire resistance. Stud spacing should be at maximum 600mm centres.

8.1.2.2 Lintels and studs

A lintel and cripple studs are to be provided to any opening other than where the stud spacing is not affected. Traditionally, multiple studs will be used to support multiple joists.

Where internal walls are made up of panels, structural continuity is to be maintained, for example by the use of a continuous top binder.

Framing joints need to be secured with a minimum of two nails per joint.

8.1.3 Beams and lintels

Beams and lintels shall be satisfactory for their purpose.

Items to be taken into account include:

- Loads and spans are to be either in accordance with manufacturers' recommendations;
- Wall and cavity thicknesses;
- Bearing capacity of the masonry supporting the lintel or beam.

8.1.3.1 Materials

Concrete or steel lintels are appropriate for use in masonry walls. Support for masonry should not be provided by timber lintels.

Lintels should extend beyond each end of openings in masonry as follows:

Span (m)	Minimum length of bearing (mm)
Up to 1.2	100
Over 1.2	150

Table 2: Minimum bearing lengths of lintels

Where structurally necessary, provide padstones under the bearings of lintels and beams. 'Steelwork support to upper floor and partitions.'

Non load-bearing partitions shall have acceptable strength and be adequately supported.

8.1.3.2 Partition construction

The following partition constructions are satisfactory:

- Partitions of brick or block construction;
- Timber stud partitions using studs, sills and head plates nominally 63mm x 38mm. Studs should be spaced to suit the thickness of plasterboard used, as follows:
 - Maximum 450mm spacing for 9.5mm boards;
 - Maximum 600mm spacing for 10mm - 20mm boards.

8.1.4 Non load-bearing timber partitions

- Partitions should be robust and form a smooth, stable, plane surface to receive decoration;
- Supporting members should be accurately spaced, aligned and levelled;
- The tolerance of horizontal straightness of a partition should be +/- 10mm over a 5m length;
- The deviation in vertical alignment of a partition in any storey height should be +/- 10mm;
- Timbers supporting plasterboard should be regularised and have a moisture content not greater than 20% at the time of erection. (Lower moisture contents can reduce the incidents of nail popping and other effects of shrinkage).

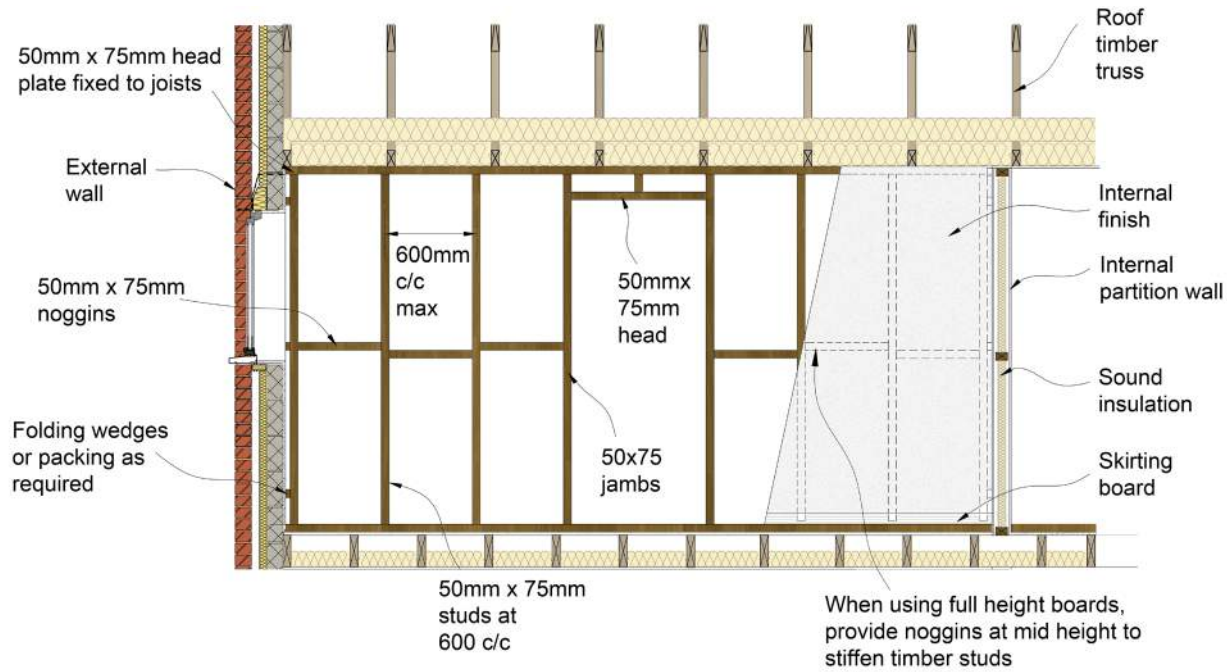

Figure 3: Timber stud partition

Stud partitions should be not less than 38mm wide and not less than 63mm thick (up to a maximum partition height of 2.4m) and 89mm thick (up to a maximum partition height of 3m). However, in order to accommodate tolerances for plasterboard fixing, a minimum width of 44mm is recommended.

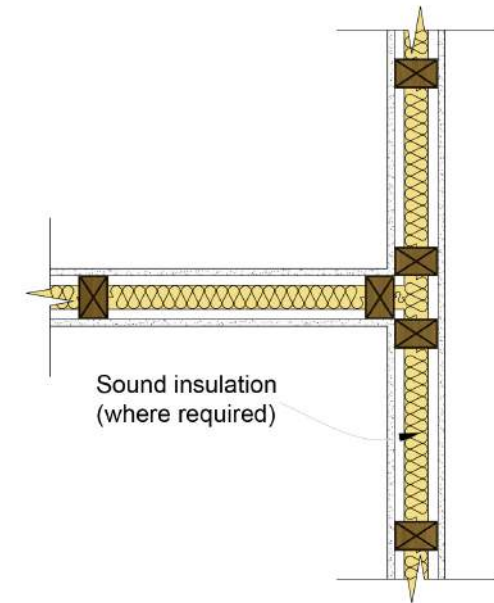

Figure 4: Typical timber stud plan

Head and sole plates should consist of single length members fixed to the building structure at not less than 600mm centres.

Partitions should be located on double joists when parallel to floor joist span and nailed to 50mm x 50mm noggins fixed between ceiling joists at 600mm centres when parallel to ceiling joist span. For short lengths of partitions (1.2m maximum)

blocking between joists at 600mm centres may be used. Intersecting head and sole plates should be skew nailed together.

Timber members should be fixed together with a minimum 2 of 75mm long x 2.65mm diameter nails.

Proprietary partitions of plasterboard, strawboard or other material must be detailed and constructed in accordance with manufacturer's recommendations.

Where partitions are to support heavy items such as radiators or kitchen cupboards, additional noggins should be provided within the stud partition to accommodate fixings.

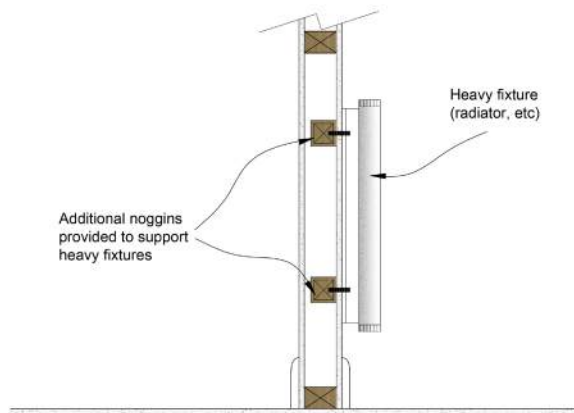

Figure 5: Support of heavy fixtures

8.1.5 Method of supporting partitions

Walls and partitions are to be supported by the structural floor only if the material is specifically manufactured for that purpose; it is not to be by a floating floor that incorporates a compressible layer.

Masonry partitions should be supported on:

- Other masonry partitions or walls (wherever conceivable, the design of dwellings should be such that the first floor masonry partitions are an extension of those on the ground floor);
- Concrete floors;
- Steel or concrete beams.

It may be necessary to use padstones at bearings where steel or concrete beams are to be used.

Masonry partitions should not be supported by timber joists or beams. Allowance should be given in the design for the relatively flexible nature of the timber and the rigid nature of masonry.

Extra noggins or joists should be specified where stud partitions or proprietary plasterboard partitions are supported by a timber floor, unless it can be shown that the deck can transfer the load without undue movement.

Allowance for the probable deflection of floors at the head of partitions is required to prevent the partition becoming load-bearing.

8.1.6 Proprietary systems

Proprietary systems are to be specified in accordance with the manufacturer's recommendations.

8.1.6.1 Metal stud system

There are a number of proprietary systems on the market.

They traditionally consist of 'U' shaped channels which act as ceiling (head), base plates (tracks) and the vertical studs. The advantages of this system are that they are lightweight, versatile and quick to erect.

Installation should always be carried out in accordance with the manufacturer's instructions. Plasterboard coverings are screw fixed to the metal studs with the perimeter studs / tracks generally being mechanically fixed to the surrounding walls, ceilings and floors.

It may be necessary to provide earth-bonding to the metal stud system.

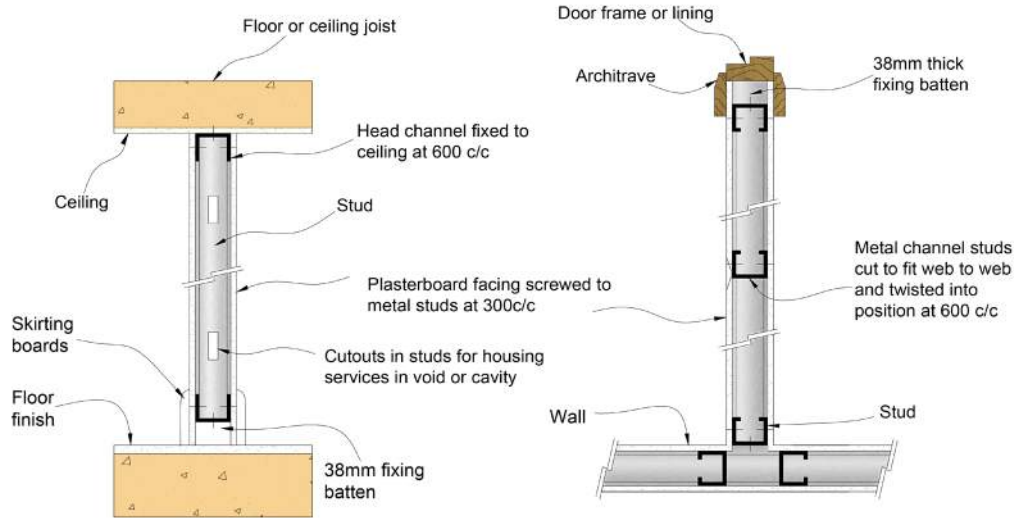

Figure 6: Metal stud partition

8.1.7 Fire resistance

Typically, in dwellings only a half hour or one hour fire resistance is required to satisfy the Building Regulations, with regard to fire separation between dwellings and / or compartments within dwellings.

Material	1/2 hour FR	1 hour FR
Brick	90mm thickness	90mm thickness
Block	90mm thickness	90mm thickness
Plasterboard on timber	12.5mm board on both sides of framing	Two layers of 12.5mm board on both sides of framing or Proprietary fire boards (typically 12.5mm-15mm) on both sides of framing
Plasterboard laminated wall	12.5mm laminated on both sides of 19mm board	Refer to manufacturers recommendations

Table 3: Minimum periods of fire resistance

8.1.8 Sound insulation

Internal walls shall, where necessary, have adequate resistance to the transmission of sound.

All separating walls in England and Wales may be built in accordance with Robust Details Part E 'Resistance to the passage of sound'.

Sound insulation can be complied with by using either:

8.1.8.1 Pre-completion testing

Pre-completion testing (PCT) is required in the following situations:

- To all new build domestic properties (including rooms for residential purposes); other than when the Developer has registered and built in accordance with Robust Standard Details;
- Where the sound insulation construction is in accordance with the guidance given in Approved Document E of the Building Regulations;
- Where the building is not built in accordance with the Approved Document E of the Building Regulations;
- The requirements of the Robust Details system have not been met.

8.1.8.2 Robust Details

The use of Robust Details as a means of providing adequate sound insulation applies only to party walls and floors between different dwellings or flats. It is approved by Robust Details Ltd. The robust design details are available in a handbook, which may be purchased from:

Robust Details Ltd.
PO Box 7289
Milton Keynes
Bucks
MK14 6ZQ

T: 0870 240 8210

w: www.robustdetails.com

Robust Details Ltd. may undertake monitoring to check on performance achieved in practice.

8.1.9 Internal plastering

Internal plastering should comply with BS 5492. Plasterboard should be to BS 1230. Plasterboard thickness should be:

- 9.5mm for stud spacing up to 450mm.
- 12.5mm for stud spacing up to 600mm.

Further guidance on plastering can be found in Chapter 10 of this Manual.

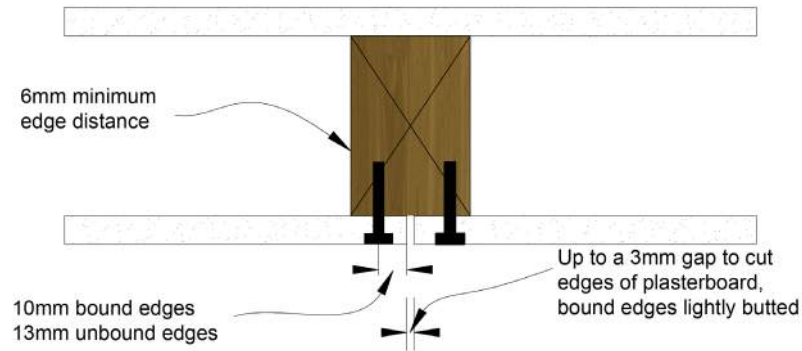

Figure 7: Fixing of plasterboard to studs

FUNCTIONAL REQUIREMENTS

8.2 INTERNAL FLOORS

Workmanship

- i. All workmanship must be within defined tolerances as defined in Chapter 1 of this Manual.
- ii. All work to be carried out by a technically competent person in a workmanlike manner.

Materials

- i. All materials should be stored correctly in a manner which will not cause damage or deterioration of the product.
- ii. All materials, products and building systems shall be appropriate and suitable for their intended purpose.
- iii. The structure shall, unless specifically agreed otherwise with the warranty provider, have a life of not less than 60 years. Individual components and assemblies, not integral to the structure, may have a lesser durability but not in any circumstances less than 15 years.

Design

- i. Design and specifications shall provide a clear indication of the design intent and demonstrate a satisfactory level of performance.
- ii. Party floors between dwellings must achieve satisfactory levels of sound insulation meeting the relevant requirements of the Building Regulations.
- iii. Structural elements outside the parameters of regional Approved Documents must be supported by structural calculations provided by a suitably qualified expert.
- iv. The materials, design and construction must meet the relevant Building Regulations and other statutory requirements, British Standards and Euro-Codes.

8.2.1 Floor boarding or decking

Suitable floor boards and decking include:

Tongue and grooved softwood flooring with a minimum moisture content at the time of fixing to be between 16-20% and be in accordance with BS 1297. All boards must be double nailed or secret nailed to each joist using nails that are at least three times the depth of the board. Boards to have a minimum thickness as indicated in Table 4.

Finished board thickness (mm)	Maximum centres of joists (mm)	Typical nail fixing
15	450	45mm lost head nail
18	600	60mm lost head nail

Table 4: Softwood floor boarding-minimum thickness and centres of support

8.2.1.1 Particle boarding

Acceptable particle boards consist of Oriented Strand Board (OSB) or Chipboard. Chipboard should be tongue and grooved and all joints glued. The boards should be laid so that the shortest length is laid parallel to the span. OSB boards should be type 3 or 4 to BS EN 300. OSB boards should be laid with its major axis at right angles to the joists. (the major axis is indicated on the OSB board by a series of arrows).

Particle boards should be either screwed or nailed to the joists at 250mm centres. Nails should be annular ring shanks that are at least three times the depth of the board.

A 10mm expansion gap should be provided around the perimeter of the floor against a wall abutment.

Thickness (mm) (chipboard)	Thickness (mm) (OSB)	Maximum span (mm)	Typical nail fixing (mm)
18 and 19	15	450	60mm annular ring shank
22	18 and 19	600	65mm annular ring shank

Table 5: Particle floor boarding-minimum thickness and centres of support

8.2.2 Floor joists

To prevent distortion of finishes, joists should be stopped from twisting over supports and provision provided to accommodate up to 10mm drying shrinkage in floor joists supported by steel beams.

It is essential that joists are not overloaded during construction. Joints in joists, rafters and purlins should only be in place over a load-bearing support, or the joint be designed by a qualified Structural Engineer.

Joists should be restrained at supports using tightly fitted strutting.

Joists should have a minimum end-bearing of 90mm, unless joist hangers are used where a 35mm bearing is acceptable (subject to manufacturer's details). Double joists should be bolted together at 600mm centres using minimum 10mm diameter bolts with large washers that will

prevent the bolt head and nut from penetrating the joist. It is recommended that bolting of double joists is along centre line of joists. Suitably sized trimmer joists shall be provided around floor openings.

Trimmed openings may be needed around staircase openings and chimneys. Solid trimmed joists may be supported using either joist hangers or a structurally designed connection; timber trimmers around openings should be of at least two members and designed by a Structural Engineer.

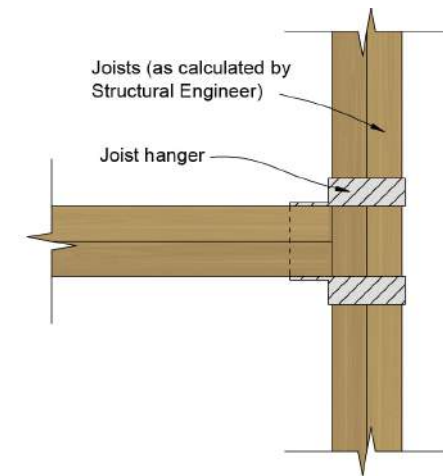

Figure 8: Typical trimming detail (plan)

8.2.2.1 Notching and drilling of joists

Joists can be notched providing it is in accordance with Figure 9.

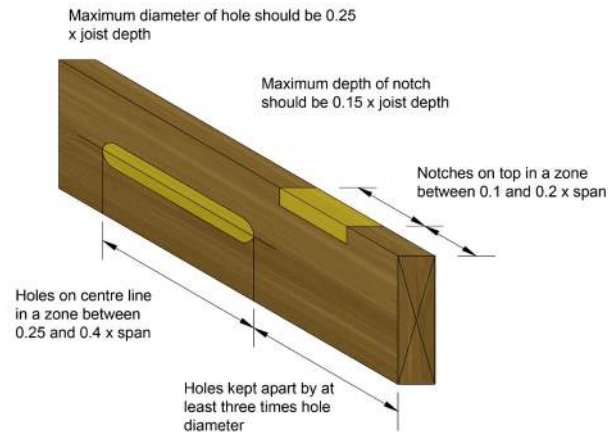

Figure 9: Notching of joists

8.2.3 I-joists

I-joists and metal web trimmed joists should be supported using joist hangers. If an I-joist is used as a trimmer to support another I-joist, backer blocks should be provided on both sides of the web of the trimmer.

Engineered timber I-joists include a timber flange (usually solid timber or LVL – Laminated Veneer Lumber) and a panel product web (usually OSB – Oriented Strand Board). They are manufactured in an assortment of depths and flange widths under controlled factory conditions to low and uniform moisture contents.

8.2.3.1 Engineered I-joists

Permanent rows of intermediate strutting are not required.

It consists of parallel stress graded timber flanges joined together with v shaped galvanised steel webs. The webs are fixed to the flanges via nail plates. The open web design gives great flexibility to run services through.

8.2.3.2 Storage of I-joists

I-joists should be protected from the elements supported on suitable bearers over a free-draining surface. Levels of exposure that is more severe than those encountered during a normal uninterrupted build programme should be addressed by the provision of suitable protection.

8.2.3.3 Bracing

Large areas of floor joists can be assembled with these products due to their light weight and availability in long lengths. It is of great importance that adequate safety bracing is provided to maintain that the joists remain stable through the construction phase.

Joist manufacturers provide simple guide recommendations which allow an installer to facilitate this process with ease and speed.

Un-braced joist layouts are not to be walked on by workers.

Floors should not become overloaded during construction.

Under no circumstances should the flanges of the I-joist be cut, notched or drilled.

8.2.3.4 Building in of I-joists over internal walls

To reduce shrinkage, all mortar should be adequately dry and should be solidly packed in but should not be packed up tight to the underside of the top flange. Before the floor decking is fixed, all continuous joists must be packed down to the intermediate bearing wall.

8.2.3.5 Pre-cast concrete floor units

Pre-cast concrete units and infill blocks are to be carefully stored and handled on-site, preventing damage occurring before, during and after incorporation into the structure. Units should be lifted as near as possible to their ends.

The bearing surface of walls, beams and other supports to receive pre-cast units are to be smooth and level.

Infill blocks and slabs should fully bear onto supporting beams and walls.

8.2.3.6 Pre-cast beam and block floors

Ensure that pre-cast concrete beam and block floors are fully supported by load-bearing walls.

Similar beams of the same size may have differing strength properties because of varying reinforcement size, so it is important to check beam reference numbers and their layout.

It is also sometimes essential to provide two or more beams adjacent to each other where spans are excessive or in heavily loaded areas. Suitable infill bricks or blocks, are to be properly bedded on mortar, and provided between PC beams where bearing onto supporting walls.

Beams and blocks are to be grouted together with a 1:6 cement / sand mix in accordance with the manufacturer's instructions.

Load-bearing walls are to continue through the beam and block floor.

Holes for service pipes are properly filled by laying non-timber formwork between PC joists and filling with good quality concrete (ST2 mix) prior to screeding.

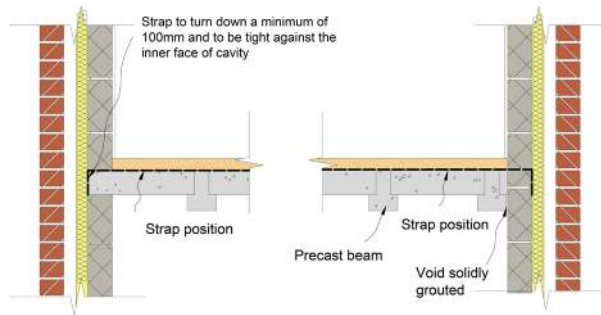

Figure 10: Lateral restraint to walls at floors and roofs (beam and block)

Beams should bear onto masonry minimum 90mm and steelwork minimum 70mm.

Provide restraint straps to walls where the beams run parallel.

Ensure that the blockwork carrying the beam and block flooring has sufficient compressive strength.

8.2.4 Fire resistance

All floors should have the fire resistance required by the relevant Building Regulations.

I-joists and metal web joists may require a different specification for the ceiling than that for solid timber joists to achieve the same fire resistance. Holes should not be made in the ceilings, e.g., for down lighters unless it can be proven that the floor construction achieves the required fire resistance.

8.2.4.1 Fire stopping

Penetrations in floors between dwellings shall be fire stopped. There is to be no holes or gaps for smoke to pass through once the fire stopping has been fitted. Where down lighters are incorporated in a ceiling they should be fitted in accordance with the manufacturer's instructions.

FUNCTIONAL REQUIREMENTS

8.3 STAIRS

Workmanship

- i. All workmanship must be within defined tolerances as defined in Chapter 1 of this Manual.
- ii. All work to be carried out by a technically competent person in a workmanlike manner.

Materials

- i. All materials should be stored correctly in a manner which will not cause damage or deterioration of the product.
- ii. All materials, products and building systems shall be appropriate and suitable for their intended purpose.
- iii. The structure shall, unless specifically agreed otherwise with the warranty provider, have a life of not less than 60 years. Individual components and assemblies, not integral to the structure, may have a lesser durability but not in any circumstances less than 15 years.

Design

- i. Design and specifications shall provide a clear indication of the design intent and demonstrate a satisfactory level of performance.
- ii. Stairs and landings must have appropriate guarding meeting the relevant Building Regulations.
- iii. Structural elements outside the parameters of regional Approved Documents must be supported by structural calculations provided by a suitably qualified expert.
- iv. The material, design and construction must meet the relevant Building Regulations and other statutory requirements, British Standards and Euro-Codes.

8.3.1 Stairways

Staircases, newels, balustrades and handrails are to be adequately fixed to avoid excessive deflection. Strings are required on staircases to securely fix to an adjacent wall. The wall should be of masonry or timber stud construction. The top tread should not be solely relied upon for fixing. It is recommended that stair strings should have fixings at 900mm centres. The fixings should be at least 6mm diameter screws which penetrate into the masonry wall or timber stud by at least 60mm.

Unless it is for a means of entrance / exit within a communal type building, there is no longer guidance given for a minimum width of a staircase. In these circumstances, the width and pitch, etc., will be determined by the use of the building.

Where a staircase serves an individual property, the need is that a safe means of access between different levels is given.

All staircases within domestic units are to have a maximum rise of 220mm with a minimum going of 220mm, although the stair pitch which is a line connecting all nosings should not exceed 42°.

The dimensions for maximum rise and minimum going should be:

Type of stairs	Maximum rise (mm)	Minimum going (mm)
Private stairs	220	220
Common stairs	190	250
Access stairs	190	250

Table 1: Minimum rise and going of stairs

At its narrowest point, the minimum width of a winder tread should be no less than 50mm.

The minimum headroom over the flight and landing should be 2m.

Handrails and guarding over the flight and landing should be established at a height of between 900mm and 1000mm. It should be non-climbable and any gap within a riser or guarding should not exceed 100mm.

Handrail design should ensure:

- A firm handhold;
 - Trapping or injuring the hand is prevented;
 - A minimum 25mm clearance at the back of the handrail;
 - Secure fixing.

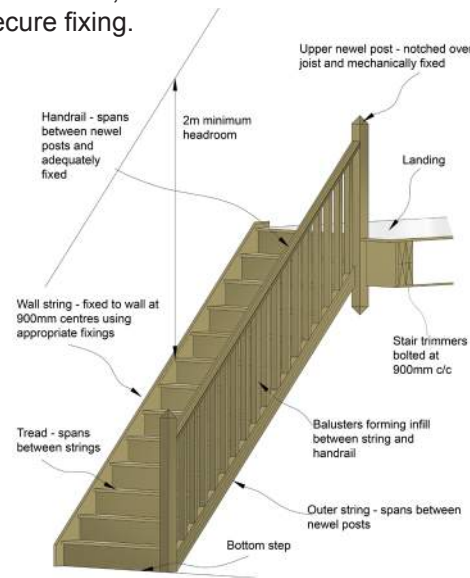

Figure 11: Staircase

Where the staircase is greater than or equal to 1000mm, a handrail should be provided to both sides of the staircase.

8.3.2 Location and fixing

8.3.2.1 Headroom

The overall floor opening is to be checked for size to accept the stairs and to allow for sufficient headroom.

The minimum headroom above the stairs is to be measured vertically from the pitch line. The clear headroom should be 2m over the entire length and width of a stairway, including landings.

8.3.2.2 Overall vertical rise

Staircases are traditionally manufactured off-site so the floor-to-floor dimensions should be extremely accurate, although an allowance should be made for floor finishes to structural floors or staircase treads.

8.3.2.3 Pitch

Staircases should be accurately located and fixed with the string at the correct angle so all treads are horizontal.

8.3.2.4 Landings

Landings are to be properly framed to provide full support to and secure fixings for flights, nosings, newels, apron linings, etc.

8.3.2.5 Floor finishes

Allowance should be made for stair and floor finishes ensuring that all risers are equal.

8.3.2.6 Pitch

The maximum angle of pitch of a stairway should not exceed:

- 42° for private stairs;
- 38° for common or access stairs.

8.3.2.7 Lighting

Artificial light sources should be provided to all staircases and landings. Within dwelling, lighting to stairs should be controlled by two way switching.

Automatic light sensitive controls may be used in common areas, provided lights can also be switched two way manually.

Where staircases are lit by glazing, any glass which immediately adjacent to the stair should be:

- Protected by a balustrade or railing, or;
- Glass (toughened or laminated), or;
- Constructed of glass blocks.